

LAYOUT

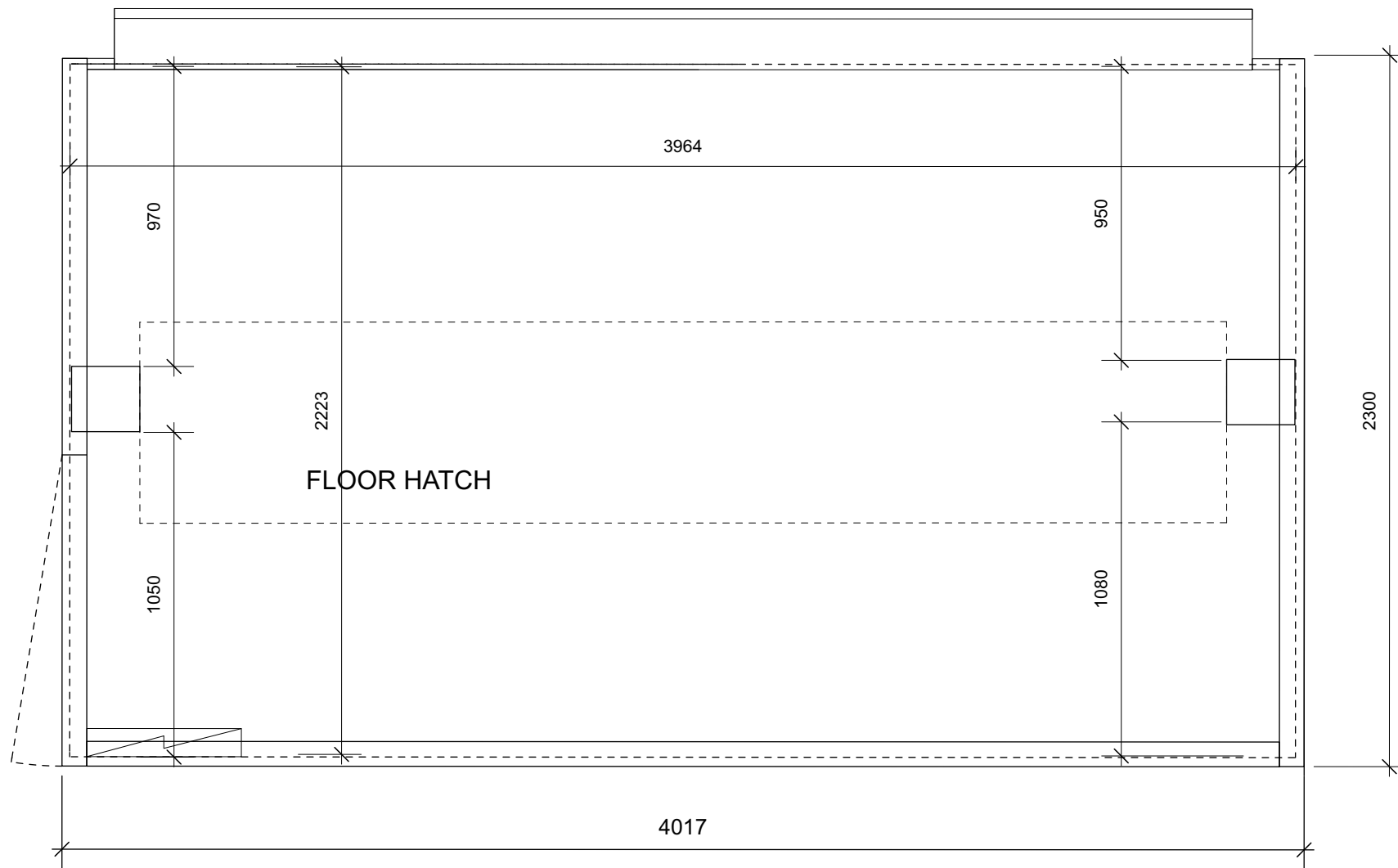

SECTION

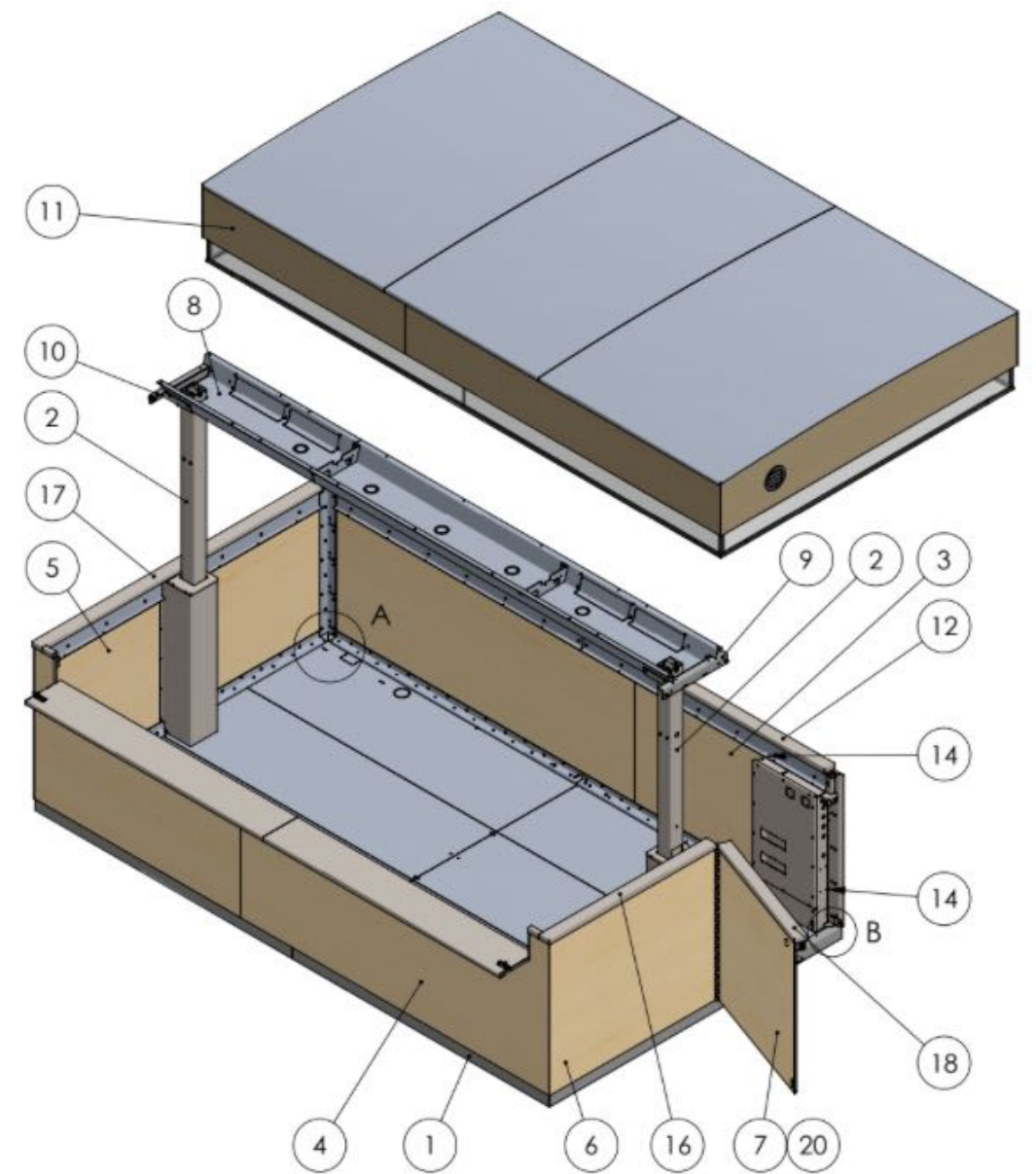
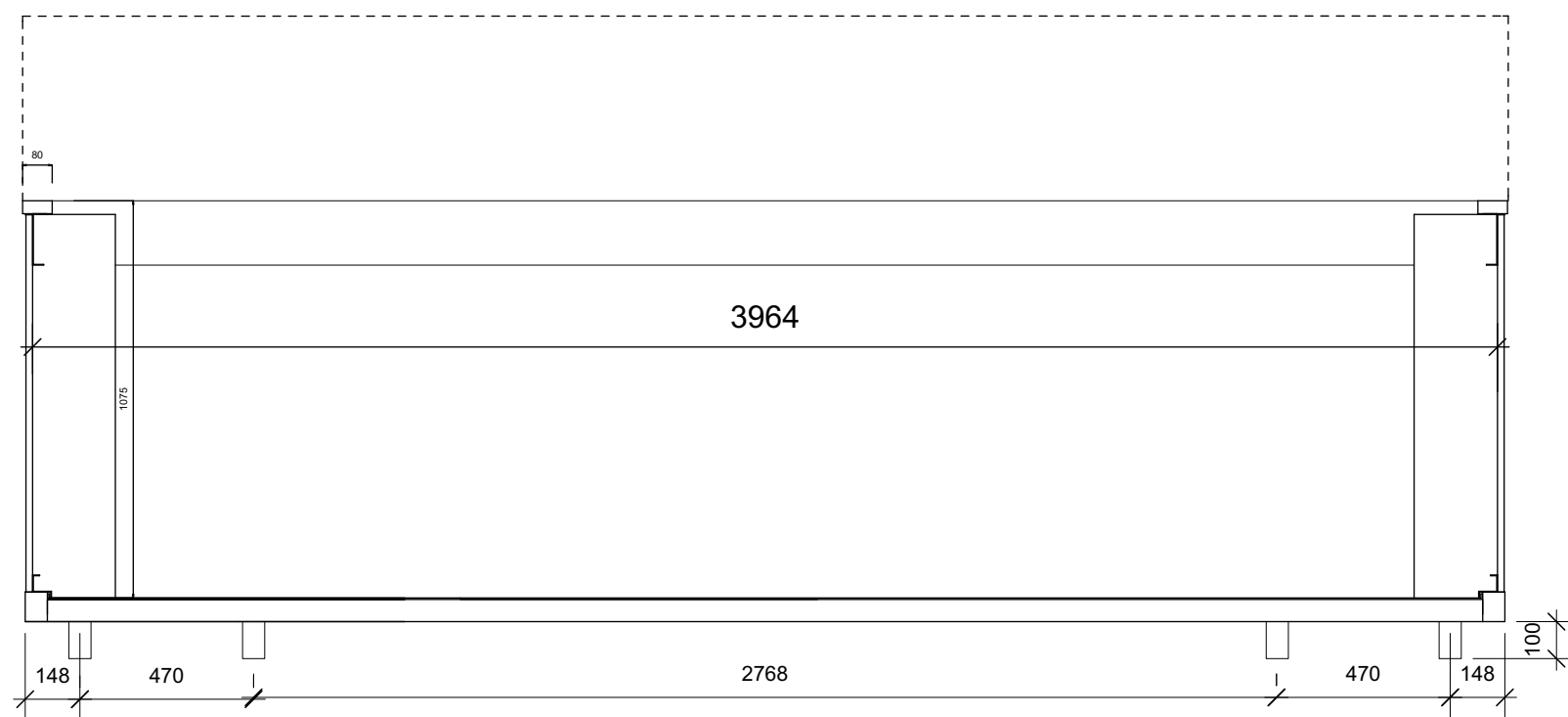

**IN THE WALLS**  
 8 PCS x 230V OUTLETS IN FRONT WALL  
 8 PCS x 230V OUTLETS IN BACK WALL  
 2 PCS x CAT CONNECTOR  
 2 PCS x USB CONNECTOR

**ON THE CEILING**  
 1 PCS JUNCTION BOX 230V  
 1 PCS CAT CONNECTOR  
 5 PCS LED LIGHTS

WEIGHT 793 KG

TOPBOX 41L



BACK VIEW

4029

4017

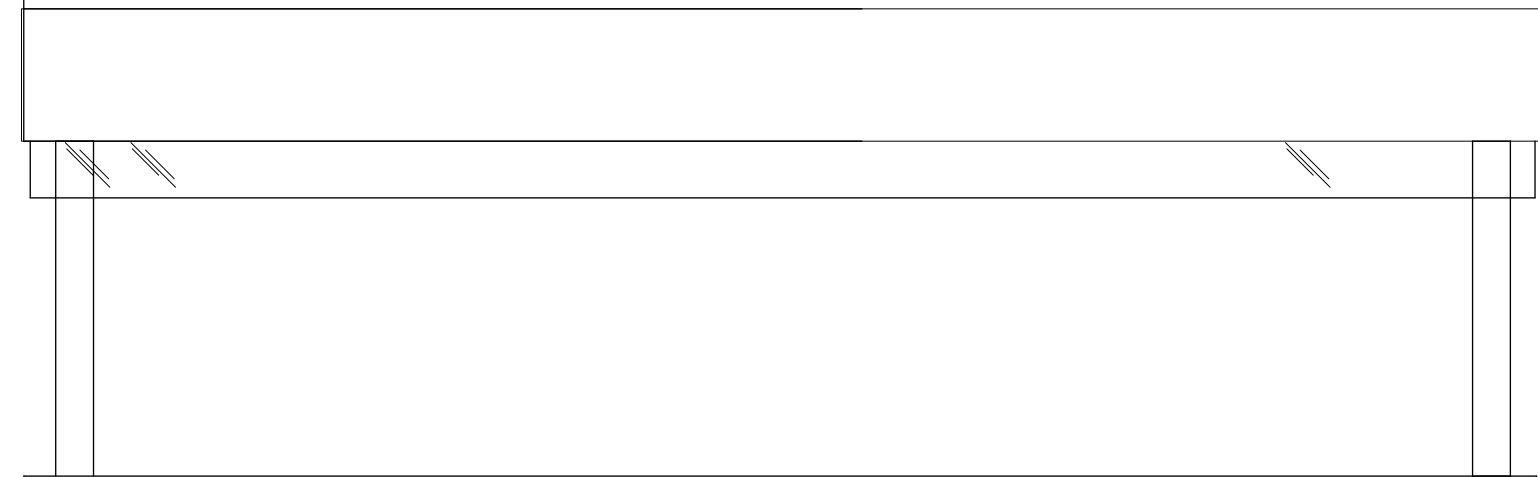

3996

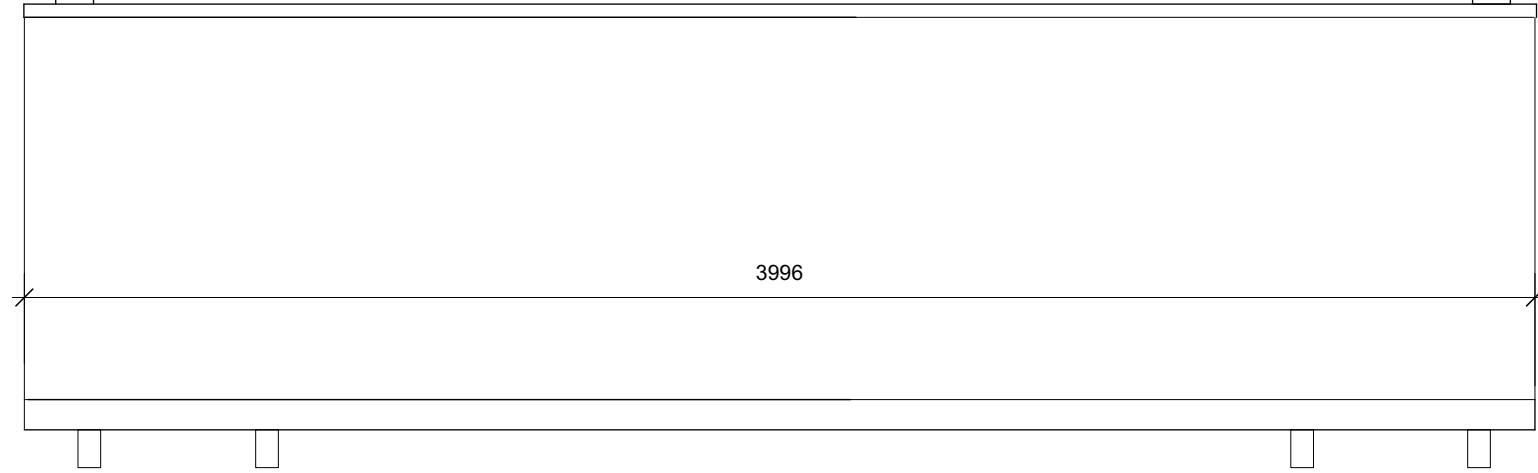

FRONT VIEW

4029



3996

825

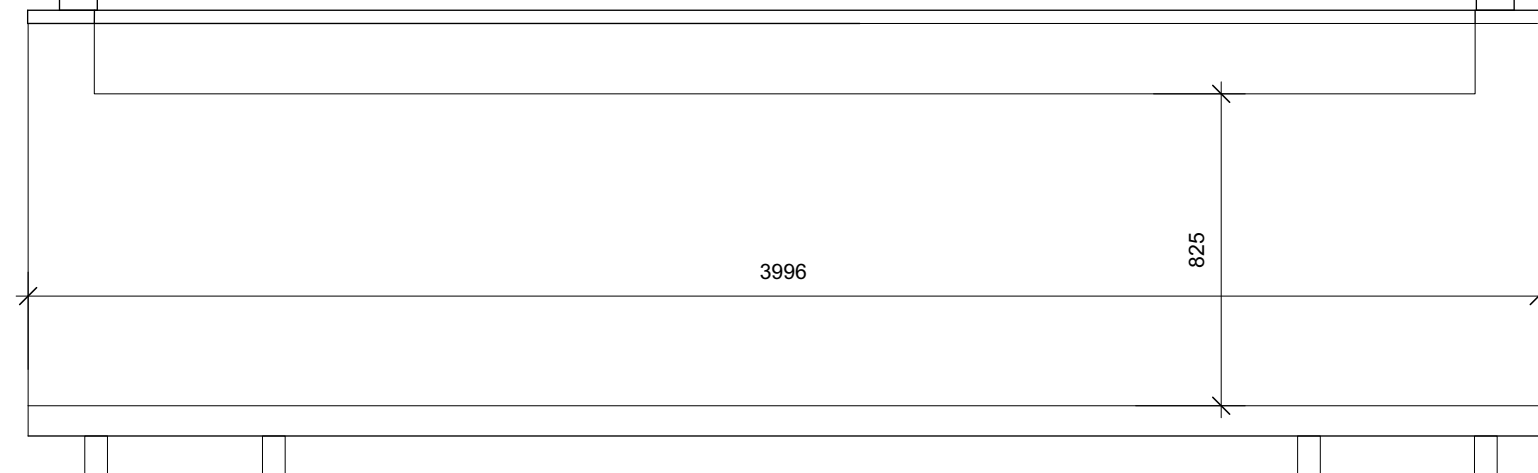

WEIGHT 793 KG

TOPBOX 41L

topbox  
ORIGINAL

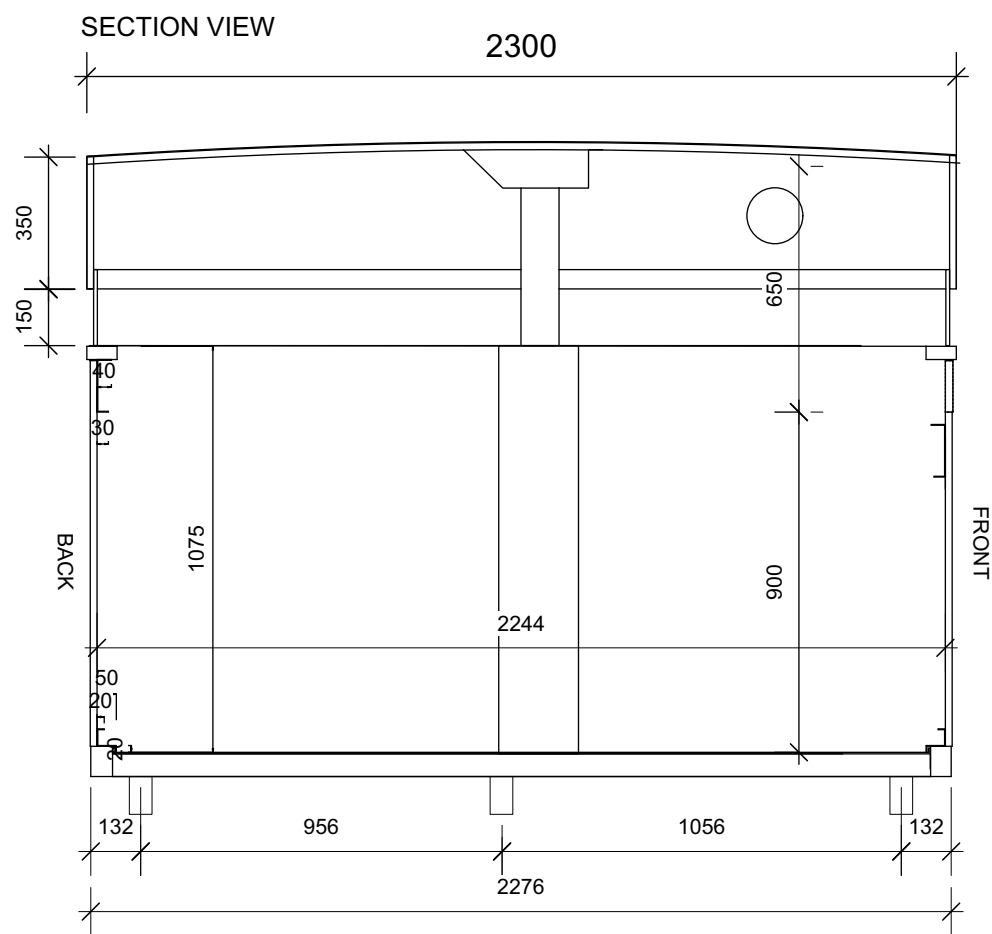
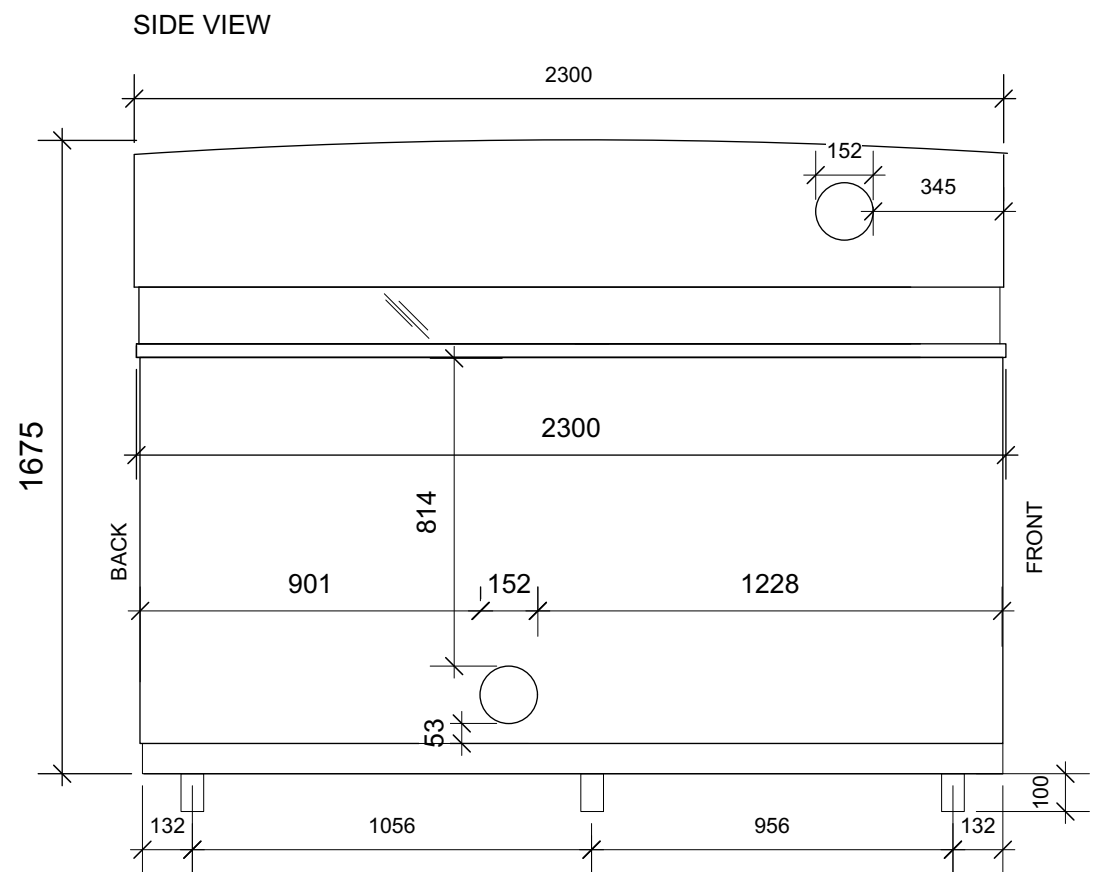
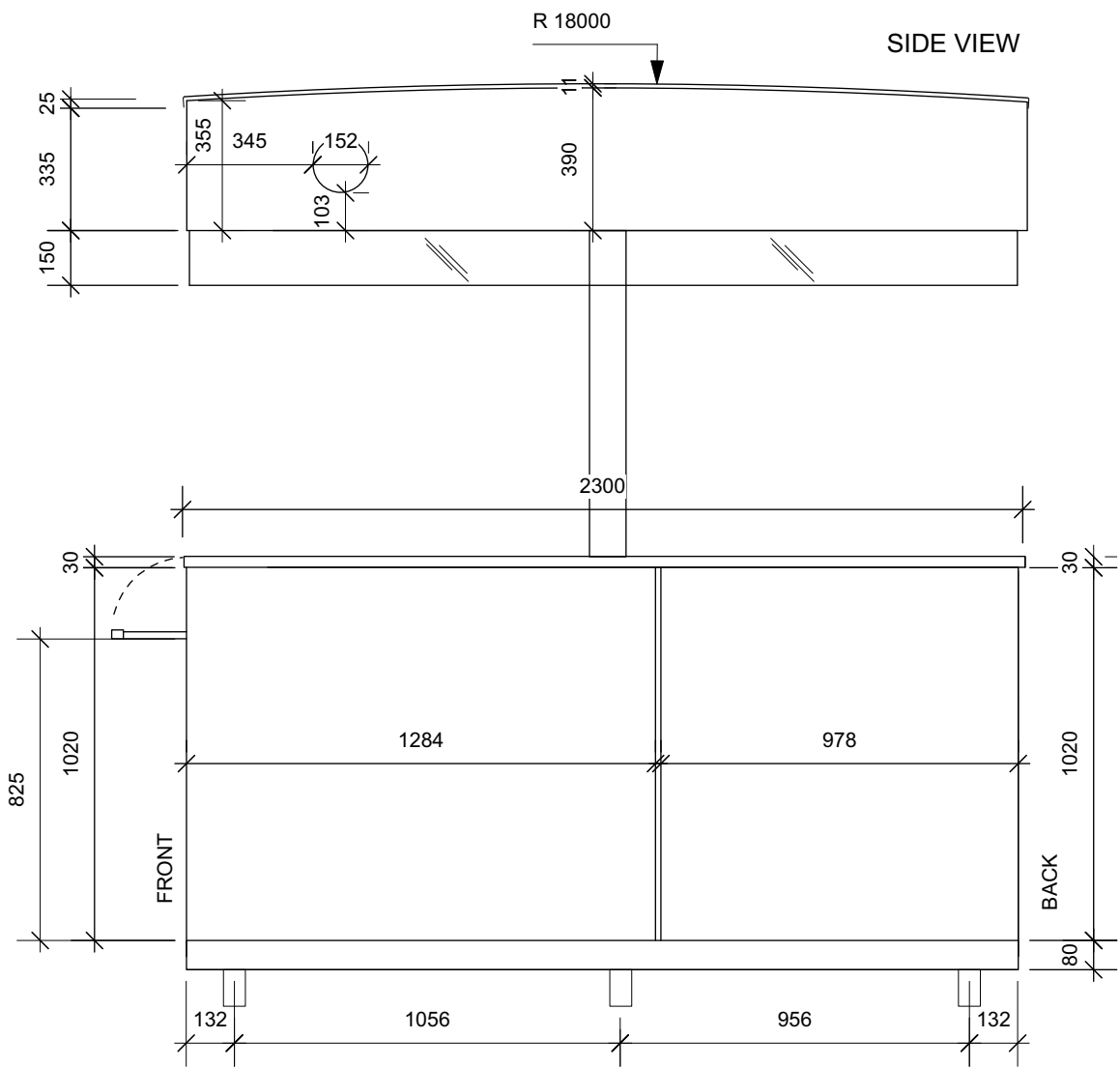

WEIGHT 793 KG

**TOPBOX 41L**

**topbox**  
ORIGINAL